

CUSTOMER SERVICE

Should you need repair, parts may be sent to:
Laurel Metal Products
3500 W. Touhy Ave.
Lincolnwood, IL 60712

Please include phone number and return address.

LIMITED WARRANTY

Laurel Metal Products warrants that the goods described in this warranty are free from defects in workmanship and materials for the period of one (1) year.

For breach of the express warranty and any implied warranty on this product, you are limited to the following damages:

If within one (1) year from the date of purchase, this product fails due to a defect in materials or workmanship, Laurel Metal will repair or replace it free of charge. In no event shall Laurel Metal be liable for incidental or consequential damages. Laurel Metals' liability for any claims arising out of this warranty shall not exceed the purchase price of the product.

NOTE: some states do not allow the exclusion or limitation of incidental or consequential damages, so the above limitation or exclusion may not apply to you.

This warranty does not cover damage resulting from accident or from misuse or alteration of the product.

The term of this warranty begins on the date the product is purchased by you, and continues for a period of one (1) year from that date.

To obtain performance of any obligation under this warranty, you must return the complete product prepaid, together with a description of the problem, approximate date of purchase, your name, address and telephone number, to the address listed above.

This warranty gives you specific legal rights, and you may also have other rights that vary from state to state.

This warranty covers any electronic vender manufactured by Laurel Metal Products.

MODEL 399

ELECTRONIC VENDER & RETROFIT KIT



LAUREL

METAL PRODUCTS INCORPORATED

3500 W. Touhy Ave.
Lincolnwood, IL 60712
Toll Free (888) 528-7358
(847) 674-0064
Fax # (847) 674-0094
www.laurelmetal.com

INSTRUCTION MANUAL

OPERATION AND SERVICE

ELECTRONIC REQUIREMENTS

24 Volt AC

The power connection for the machine is on the circuit board. The terminal block for incoming power is located on the lower left corner of the Circuit Board. You will have to lift up the Cover/Instruction sheet to locate this terminal block, which is black in color.

BE CERTAIN TO SUPPLY 24 VOLTS/AC

TRANSFORMER POWER REQUIREMENTS

The minimum power required for each vender is 1/2 amp (500mA). To run multiple venders on a transformer first determine the total amperage required, taking into account future additions. To determine the amperage output of a 24 volt transformer that is given in VA, divide the VA output by 24. For example, a 100 VA transformer would provide 4.2 amps ($100 \div 24$) of 24 volts AC power. This would be ample power for 8 venders.

INSTALLATION

The vender can be mounted on any vertical surface without removing any part of the unit. Any standard fastener not larger than 3/8" diameter such as wood screws, expansion bolts, machine bolts or carriage bolts can be used depending on the type of wall. The vender weighs 45 lbs. empty.

The top two fasteners should be loosely installed in the wall with the heads of the fasteners projecting out approximately 1/4" from the wall. Raise the top shelf of the magazine into its vend position to expose one of the two top mounting holes in the back of the cabinet. The keyhole shape of the mounting holes will permit you to hang the cabinet on the two fasteners. While in this unsecured position, mark the bottom two mounting holes on the wall to accurately align the lower fasteners, if necessary remove the cabinet. Install the bottom fasteners to secure the cabinet.

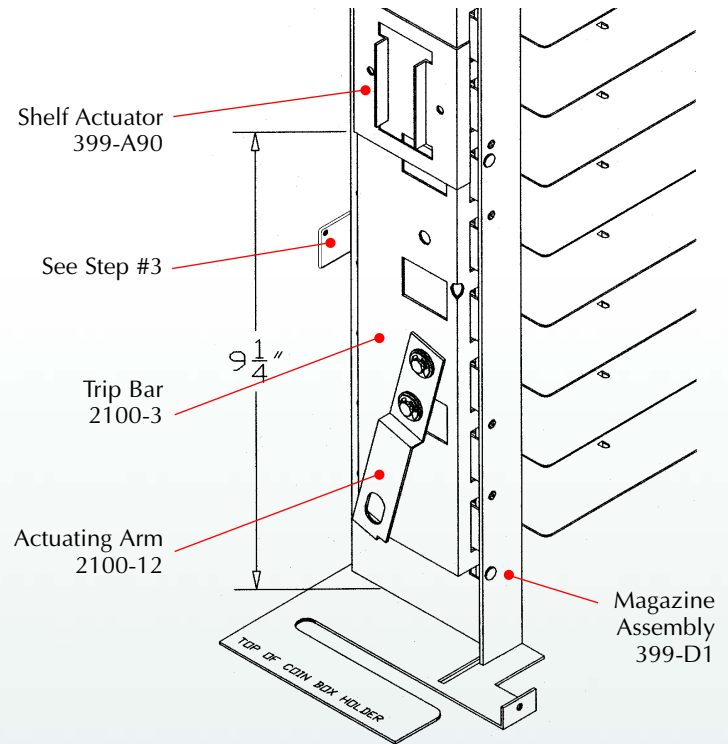

RETROFIT KIT INSTRUCTIONS

You do not need to take down your mounted cabinet. Also, the Magazine Assembly can stay mounted inside the Cabinet.

1. Remove existing Door and Security Frame from the Cabinet. Assemble new Door on existing Cabinet and replace the Security Frame from your old Door.
2. Remove 3 screws holding mechanical Coin Mechanism. Loosely reinstall these 3 screws. Now remove existing Empty Lock Rod, which is hanging down the left side of the Magazine Assembly. This Rod will not be needed.
3. Detach Spring from side of Magazine Assembly – this is not needed in new electronic system.
4. Shelf Actuator has double faced tape applied to it, you need to peel back the top layer to expose the adhesive. Now apply the Actuator on to the Trip Bar at the dimension indicated in the diagram – (9 1/4" from the top of the Coin Box Holder to the bottom of the Actuator)
5. Drill 1/4" – 1/2" hole in back of Cabinet to be used for bringing the power cord in. **Leave ample extra wire.**
6. Mount electronic Coin Mechanism over the 3 screws you loosely installed in Step #2 and tighten screws. The keyhole shape of the holes in the Coin Mechanism front flange allow you to remove and install the Coin Mechanism without taking the screws out.

IMPORTANT – when installing the new Coin Mechanism the round cam of the Vend Motor must go inside of the Shelf Actuator's flanges.

7. To install new Empty Rod it is recommended to first insert bottom of Rod through the guide hole at the top of the Coin Mechanism (above the Empty Switch). Now insert top of Rod as before (identical to mechanical system). Before resetting the shelves lift rod up to see if it falls freely and trips the Empty Switch.

Circuit Board
399-19

Empty Switch
399-15

Wire Harness
399-16

Vend Motor
399-10

Upper Coin
Chute
399-A4

Electronic Acceptor
Sensortron 399-13
MA-800 399-64
Microcoin QL
399-101

Lower Coin Chute
1 coin 399-A6
6 coin 399-A66

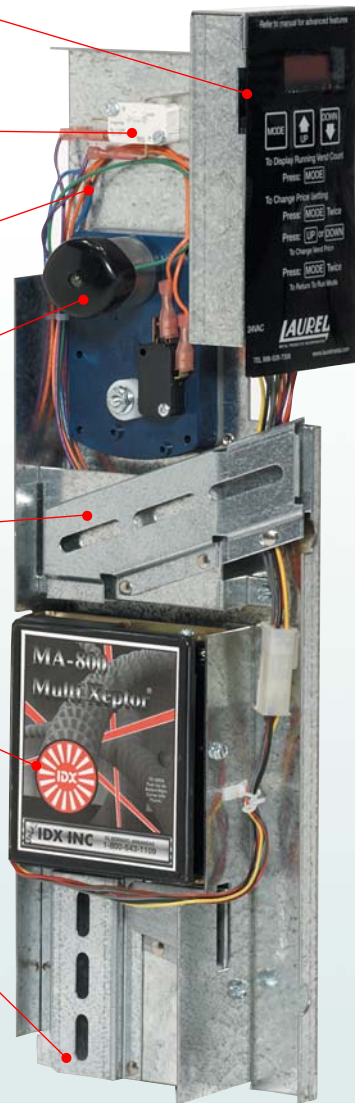

COIN MECHANISM FEATURES

The vend count is displayed when the **MODE** button is pressed once. The number displayed is the total number of products sold since initial installation of this vender. The counter is non-resettable so it can't be tampered with. You can now implement inventory control on your vending products.

The vender will be factory set to vend at \$1.00 (or \$2.00 for the bottle vender). To change the vend price, press the **MODE** button 2 times, the display will show a 'P' and the current price setting. Now change the price with the **UP** or **DOWN** buttons and press the **MODE** button once more to cycle back to the 'run' mode.

Pricing is adjustable from 25¢ to \$9.75.

COIN ACCEPTORS

• SENSORTRON – SINGLE COIN



This acceptor sends 1 credit pulse to the LED display for every coin or token entered. The factory setting is \$0.25 for every credit. This can be changed if quarters are not accepted. For instance, if a token with \$0.50 value is only to be accepted, then the base coin credit value (the 'A' value) must be changed to 0.50. To change this value, press and hold the **MODE** button until the LED display reads **A .25**. Now use the **UP** or **DOWN** buttons to change. Press the **MODE** button to return to the run mode.

If dollar coins are only to be accepted, then follow the same steps and change the 'A' value to 1.00. **Remember to insert a sample coin into the coil of the Sensortron.**

• MA-800 – MULTI-COIN



This acceptor will take up to 6 different coins, or tokens, and the value of any coin can be programmed in. Quarters are pre-programmed in switch #6 and dollar coins in #5. Refer to the enclosed MA-800 instruction manual for programming instructions if tokens or any other coins are to be accepted.

When programming in any new coins, it is recommended to remove the acceptor from the coin mechanism frame and drop the 6 sample coins in by hand. Optimal programming will be obtained by dropping the coins in the acceptor by hand rather than by running the sample coins down the metal coin chute.

To remove the MA-800 acceptor from the coin mechanism frame, loosen the 2 mounting screws on the front face of the coin mechanism, unplug the white ribbon cable, then lift up the coin mechanism to detach it. Remove the 1 screw holding the MA800 in place and pull it out to begin the programming. **Do not unplug the MA-800 from the circuit board when programming, as it needs power to operate.**

MICROCOIN QL - MULTI-COIN



This acceptor will take up to 12 different coins, or tokens, and the value of any coin can be programmed in. Quarters are pre-programmed in switch #10 and dollar coins are in #11. Refer to the enclosed QL instruction manual for programming instructions if tokens or any other coins are to be accepted. **Do not unplug the QL from the circuit board when programming, as it needs power to operate.**

COIN MECHANISM REMOVAL

To remove the Coin Mechanism, first remove the Empty Rod by dropping the top 2 shelves and disengaging the Rod from the slot at the side and top of the Magazine Assembly. To drop a shelf, use your finger under the shelf to push the Shelf Wire back out of the slot. Removing the Rod prevents the lever on the Empty Switch from getting bent when the Coin Mechanism is lifted upward upon removal.

Loosen, but do not remove, the 3 mounting screws and simply lift the Coin Mechanism up far enough for the Drive Cam to clear the Shelf Actuator.

When reinstalling the Coin Mechanism make sure that the Drive Cam is positioned back into the Shelf Actuator. If the Drive Cam is not inside of the Shelf Actuator the coin mechanism frame will not fit flush against the Shelf Assembly.

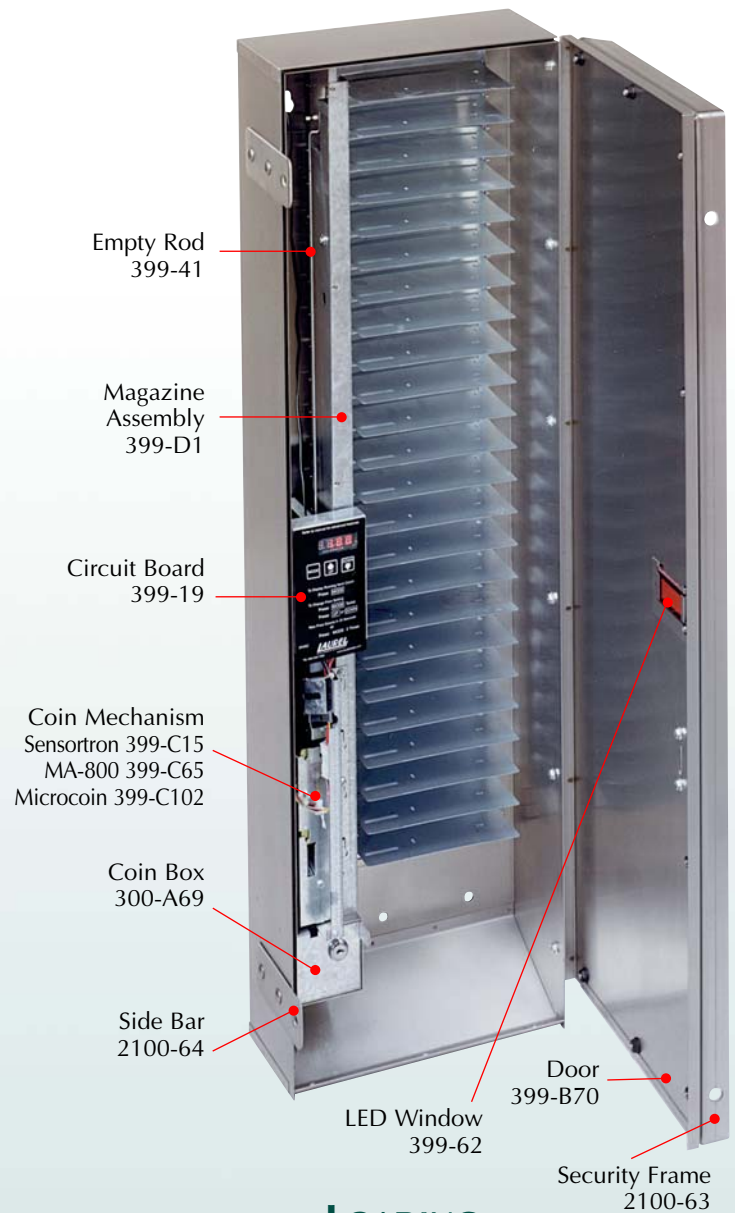

TROUBLESHOOTING

SYMPTOMS	LOOK FOR	NOTES
LED display out	Power loss Check for 24 volts (+/- 15%) power at the circuit board where power comes in	Check transformer. See page 1 for power requirements.
Power down machine for 5-10 seconds and power back up		
'E_1' displayed	Shelf stuck, jammed Motor burned out	Check shelf that is next to drop. Not very likely.
Power down machine for 5-10 seconds and power back up		
Product vended at less than vend price	'A' value changed from '.25' MA800 coin acceptor not programmed correctly	See page 5 for 'A' value setting info. See page 5 or MA800 manual.
Motor runs, no shelf drop	Shelf wire damaged, stuck	Wire tension may be too great, bend wire back slightly to lessen initial wire tension.
Inserted coin rejected	Power loss Coin acceptor malfunction Top shelf down	Check transformer. Sensortron – change sample Quarter. MA800 – see manual, LED should be green on MA800. Display will read 'SOLD OUT'.

LOADING

The shelves can be easily and quickly reset into the vend position (horizontal) by running the index finger of your right hand up the side of the shelves. This "fanning" will take only seconds to reset all 24 shelves.

The top shelf has an automatic empty device, the Empty Rod, which can be seen to the left of the Shelf Assembly, above the Coin Mechanism. When the last product is sold and this top shelf drops, the bottom of the Empty Rod trips the Empty Switch causing the Electronic Acceptor to reject all coins. The display will continually flash **SOLD** & **OUT** also. Therefore, it is extremely important to load product from the top down if the vender will not be fully loaded during restocking. Coins will be returned if the vender is sold out or if there is a power outage.