

Hamilton Manufacturing Corporation

1026 Hamilton Dr. Holland, OH 43528 • Phone: 419-867-4858/800-837-5561 • Fax: 419-867-4867 • www.hamiltonmfg.com

RNS, DRS, & ER-60 M-Line Operational Manual

TABLE OF CONTENTS

I. INSTALLATION	4
Mounting	4
Electrical	4
II. VALIDATOR MOUNTING	5-10
STA Mounting Instructions	5
STA/Stacker Mounting Diagram	6
Coinco®/Mars® Mounting Instructions	7
Coinco® Parts Layout	8
Mars® Parts Layout	9
Parts Index	10
III. PARTS	11-12

APPENDICES

APPENDIX A - 1-H Harness Diagram.....	13
APPENDIX B - Bill Denomination Mylar Instructions	14

ABOUT THIS MANUAL

This manual will provide the operator with important information about installing and maintaining the RNS, ER-60 or DRS Changer. Information is also provided for the Hopper, Stacker, and Controller. Basic mounting information is provided for the Validator(s). For further information, please refer to the appropriate Validator manual. To obtain assistance from the manufacturer, please call (800) 837-5561 or (419) 867-4858.

When calling for assistance, it is very important to have serial numbers readily available. Please record these numbers in the spaces provided. (Note that the DRS has dual components.)

RNS / DRS / ER-60 SERIAL # _____

VALIDATOR MODEL, SERIAL & VERSION # _____
(MODEL DRS) # _____

SINGLE STACKER SERIAL # _____
(MODEL DRS) # _____

DUAL STACKER SERIAL # _____
(MODEL DRS) # _____

HOPPER SERIAL # _____
(MODEL DRS) # _____

CONTROLLER MODEL, SERIAL & VERSION # _____
(MODEL DRS) # _____

KEY / LOCK # _____

Please complete the warranty card, which was included with your changer, and return it to the manufacturer.

I. Installation

Mounting

1. DURING INSTALLATION, REMOVE ALL MAJOR COMPONENTS FROM THE CHANGER.
2. Cut an opening in the wall measuring a minimum of 34-⁵/₈" H x 9" W for RNS, 34-³/₄" H x 18-¹/₈" W for DRS and 20-³/₄" H x 15" W for ER-60.
3. Caulk around the outside edge of the opening.
4. Place the cabinet in the opening and press until the flange is flush on all sides.
5. Fasten the cabinet by bolting or welding a 2" angle iron on both sides of the cabinet.

Hamilton will not be responsible for injury due to improper installation.

FACEPLATE: 38 ⁵/₈" H x 12" W for RNS, 38 ¹/₄" H x 21 ⁵/₈" W for DRS and 24-³/₄" H x 18" W for ER-60.

Electrical

This changer is operated on 120 VAC, 60 Hz. This changer uses a 5 AMP CIRCUIT BREAKER. This unit may be hard-wired with conduit if desired. **A GROUND FAULT INTERRUPTER IS REQUIRED.** The recommended Ground Fault Interrupter should have the following specifications:

- 120 VAC
- 15 AMP
- 6-10mA trip level
- Should **not** trip when power is removed from circuit.

Attached to the main harness is a 1-pin white Molex connected to a white wire. There should be a bright yellow tag attached to this wire with the following warning:

WARNING: For security reasons, this plug should remain disconnected until such time as you need to utilize the hopper's manual run switch.

There is no need to connect this plug for normal operation. If for some reason you wish to utilize the manual run switch, be sure to unplug the Molex afterward.

II. Validator Mounting

STA Mounting Instructions

1. Unplug the power cord or remove all power from the system at the circuit breaker.
2. Remove the existing Stacker and Validator.
3. Remove the Validator bracket from the mounting studs located on the front wall of the cabinet. Disconnect the heater pad (if present) and remove it as well.
4. Secure the new Validator mounting bracket assembly (37-0055B) to the studs on the front wall of the cabinet using four 1/4-20 nuts.
5. Secure the adhesive backed foam seal to the inside of the cabinet front around the Validator opening.
6. Connect the small end of the 9-pin harness adapter to the STA Validator and the other end to the system harness.
7. Slide the Validator into the Validator bracket from the rear.
8. Connect the Stacker harness and hang the Stacker from the back of the Validator mounting bracket.

STA/Stacker Mounting

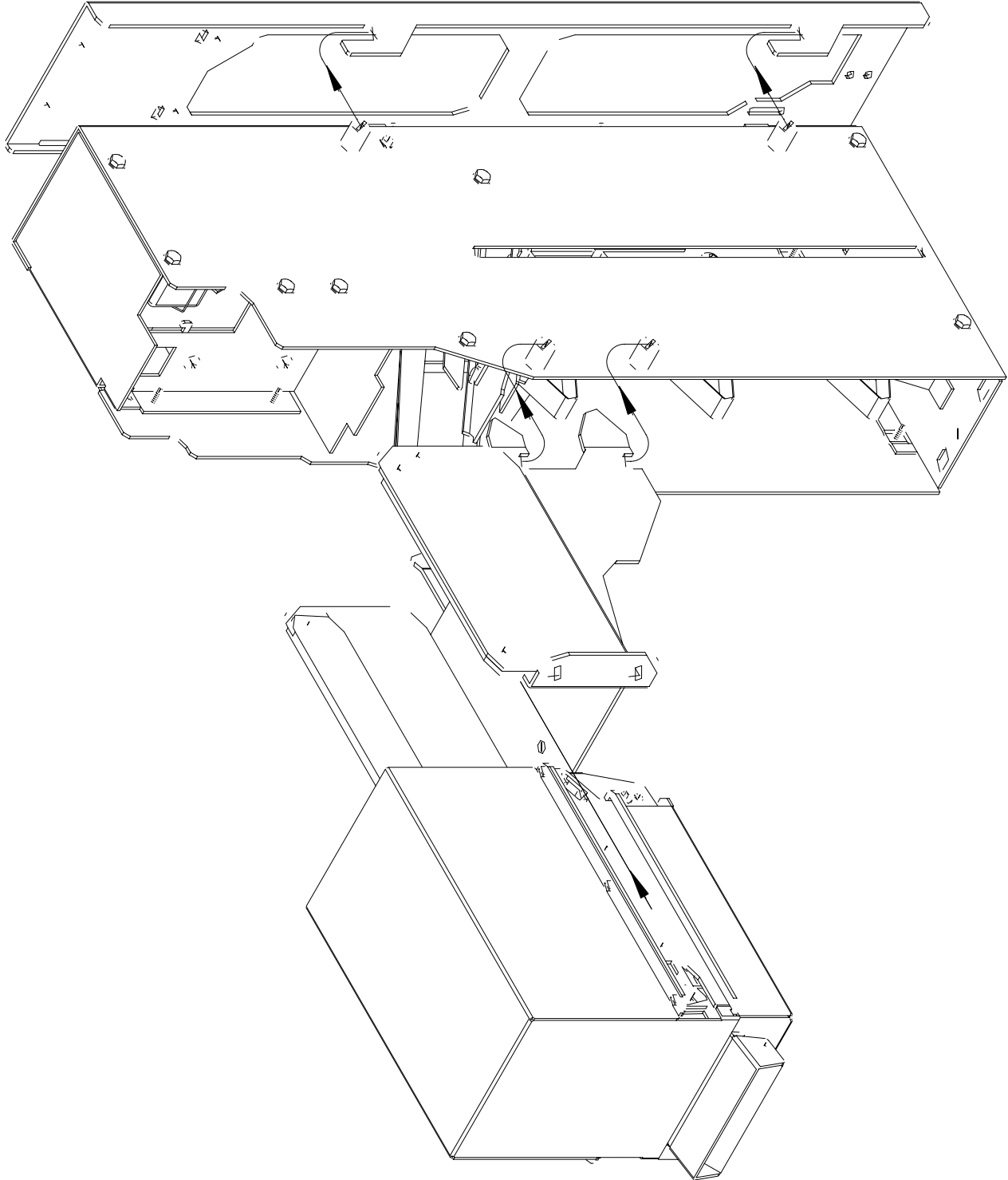

Coinco®/Mars® Mounting Instructions

In the following section, part quantities are represented by paranthesis and the # indicates the index number according to the diagram on pages 8-9.

1. Mount Cover Plate-#14 to Filler Plate-#12 using (2) 10-24 x $\frac{3}{8}$ Philips head screws-#13.
2. Then mount to face of cabinet using (4) $\frac{1}{4}$ -20 Hex nuts-#3 and (4) internal lock washers-#4.
3. Take Slider-#9 and Validator Face Plate-#10 and insert (4) 8-32 x $\frac{5}{8}$ ball studs-#11 through Face Plate and insert into front of cabinet. Then take (4) 8-32 nylon nuts-#8 and tighten on ball studs.
4. Mount (4) 10-32 x $\frac{3}{16}$ Phillister head screws-#17 to Validator Plate-#7. Screwing them from inside to out.
5. Then mount Security Bracket-#1 to the bottom of the two Phillister head screws so it swings up and down.
6. Take U-Channel-#5 and place it inside of Validator Plate-#7 and match up with studs on face of cabinet.
7. Then by taking (4) $\frac{1}{4}$ -20 Hex nuts-#3 and (4) $\frac{1}{4}$ internal lock washers-#4, mount to cabinet and tighten down.
8. Then take Validator and place into U-Channel-#5 and mount it with (4) 8-32 x $\frac{5}{8}$ Philips head screws-#2. Then swing Security Plate-#1 up and hook onto the top two Phillister head screws-#17 of Validator Plate-#7.
9. For the Coinco® Validator only, take Power Pack Holder-#15 and mount to studs on door using (2) 6-32 Hex nuts-#16.
10. For the Mars® Validator only, Take Relay Box-#15 and mount above Power Box on face of cabinet using (2) 10-24 nylon lock nuts-#16.

Coinco® Parts Layout

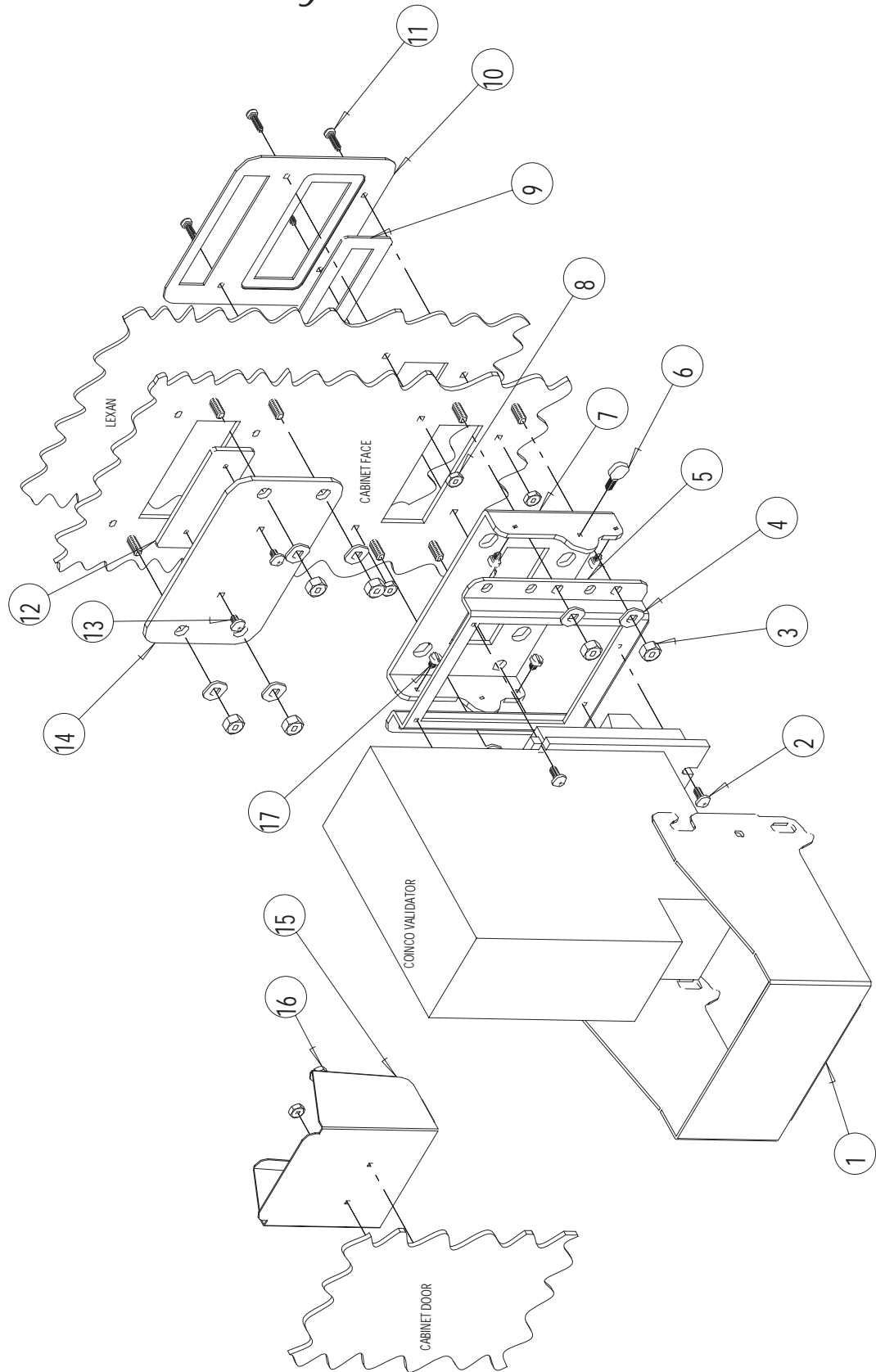

Mars® Parts Layout

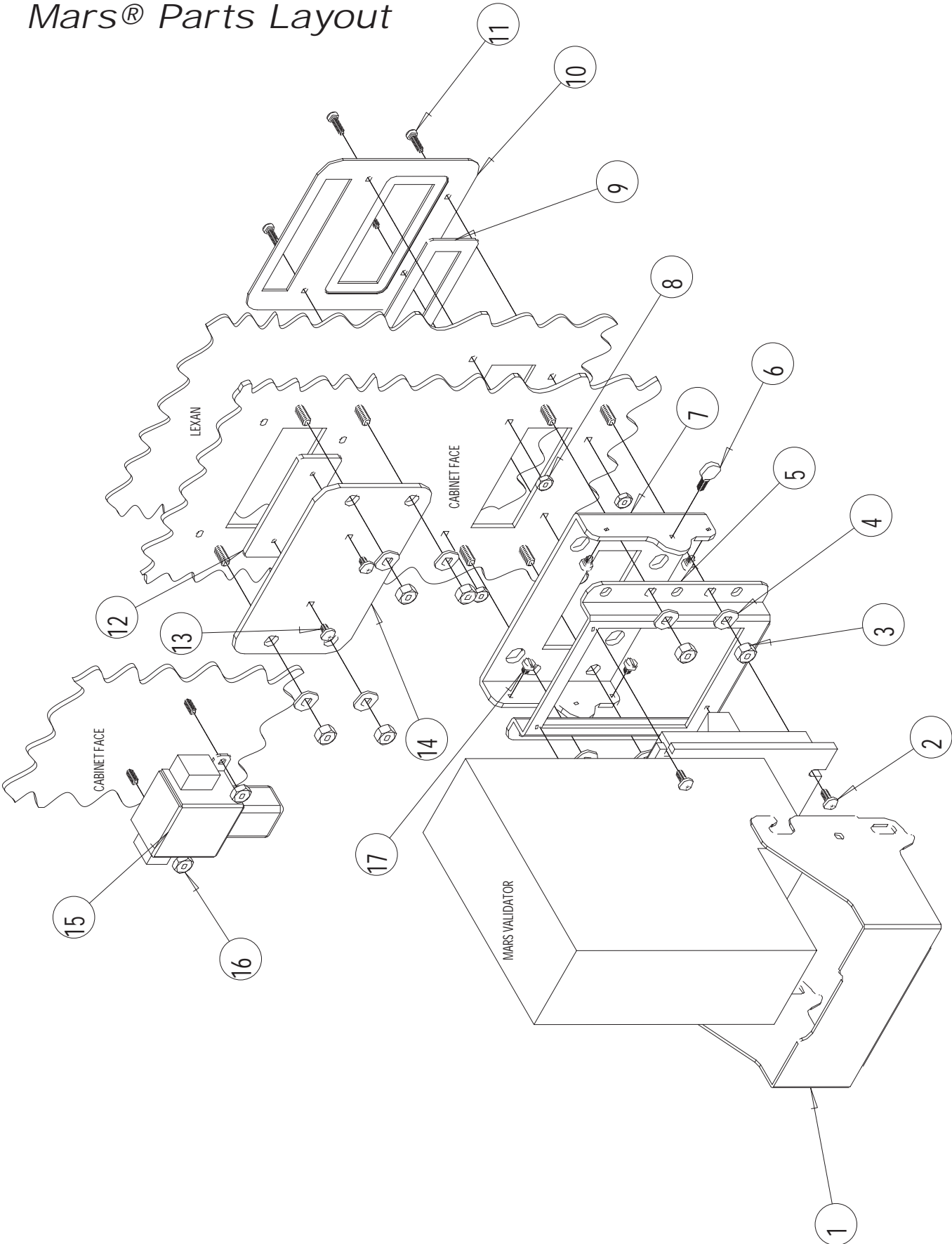

Parts Index

ITEM #	PART #	MOUNTING PARTS FOR COINCO	QTY.
1	60-2053	SECURITY BRACKET	1
2	90-0145	#8-32 X 5/8 PHILLIPS HEAD SCREW	4
3	90-0331	#1/4-20 HEX NUT	4
4	90-0403	#1/4 INTERNAL LOCK WASHER	4
5	60-2051	U-CHANNEL	1
6	90-0629	#10-32 X 1/2 THUMB SCREW	1
7	60-2050	VALIDATOR PLATE	1
9	60-2054	SLIDER	1
10	60-0282	VALIDATOR FACE PLATE	1
11	90-0517	#8-32 X 5/8 BALL STUD	4
13	90-0148	#10-24 X 3/8 PHILLIPS HEAD SCREW	2
17	90-0628	#10-32 X 3/16 PHILLISTER HEAD	4

ITEM #	PART #	MOUNTING PARTS FOR MARS	QTY.
1	60-2055	SECURITY BRACKET	1
2	90-0145	#8-32 X 5/8 PHILLIPS HEAD SCREW	4
3	90-0331	#1/4-20 HEX NUT	4
4	90-0403	#1/4 INTERNAL LOCK WASHER	4
5	60-2051	U-CHANNEL	1
6	90-0629	#10-32 X 1/2 THUMB SCREW	1
7	60-2050	VALIDATOR PLATE	1
8	90-0321	#8-32 NYLON NUT	4
9	60-2052	UVM SLIDER	1
10	60-0282	VALIDATOR FACE PLATE	1
11	90-0517	#8-32 X 5/8 BALL STUD	4
13	90-0148	#10-24 X 3/8 PHILLIPS HEAD SCREW	2
17	90-0628	#10-32 X 3/16 PHILLISTER HEAD	4

III. Parts

The following parts are standard equipment. All quantities are doubled for the DRS unless noted otherwise.

PART #	DESCRIPTION	QTY.
11-0033	HOPPER PIVOT BRACKET	1
11-0100	HSH-Q HOPPER (RNS, DRS)	1
11-0103	HSH-60Q HOPPER (ER-60)	1
47-0029	3/8" CONDUIT CONNECTOR	1
47-0077	CHANGER GROUND TERMINAL	3
47-0080	OUT OF SERVICE LAMP	1
47-0080A	SPEED NUT, TINNEMAN	1
47-0216	A.C. LINE CORD	1
47-0217	LINE CORD, EXTERNAL	1
47-0232	PANDUIT MOUNTING PADS	7
47-0275	6" CABLE TIES	8
48-0033A	STACKER BYPASS PLUG	1
48-0050	POWER BOX HARNESS	1
48-0051A	GROUND STRAP HARNESS	1
48-0090	OUT OF SERVICE HARNESS	1
48-1005	1-H HARNESS	1
49-1022A	5 AMP POWER BOX COMPLETE	1
49-2000A	C2000 CONTROLLER	1
	OR	
49-2004A	AUDIT PRO CONTROLLER	1
49-2010A	AUDIT PRO HANDHELD REMOTE	1
48-2111A	AUDIT PRO HARNESS	1
60-0084	COVER, LOCK UNISTRUT BRACKET	2
60-0346A	DRS ACCESS SHIELD	1
60-0347A	RNS ACCESS SHIELD	1
60-0349A	ER-60 ACCESS SHIELD	1
61-2000A	ER-60-M CABINET COMPLETE	1
61-2002A	DRS-M CABINET COMPLETE	1
61-2003A	RNS-M CABINET COMPLETE	1
63-0318A	WEATHERSHIELD ASSM.	1
63-2001B	ER-60-M FACE PANEL ASSM.	1
63-2002B	DRS-M FACE PANEL ASSM.	1
63-2003B	RNS-M FACE PANEL ASSM.	1
63-5005	LOCK INSERTS (1 PAIR FOR ANY MODEL MACHINE)	1
63-5006	LOCK BARRELS (QTY. 2 FOR ANY MODEL MACHINE)	2
90-0248	8-32 x 3/8" THUMBSCREW	1
90-0250	CONTROLLER MOUNTING STUD	1
90-0267	#6-32 X 3/16 SET SCREW	2
90-0275	LOCK BOLT	2
90-0301	10-24 x 3/8" NUT	4
90-0302	10-24 NYLON LOCK NUT	4
90-0331	1/4"-20 HEX NUT	8
90-0336	LOCK NUT, SQUARE (SPRING LOADED)	2
90-0356	LOCK NUT, 10-24	2
90-0403	1/4" LOCK WASHER	7
90-0429	1/4" x 3/4" WASHER	4
90-0612	WASHER, INTERNAL LOCK #10	8

The following parts are optional equipment. All quantities are doubled for the DRS unless otherwise noted.

PART #	STACKERS	QTY.
36-0036	SINGLE STACKER	1
35-0100	DUAL STACKER	1

PART #	VALIDATORS	QTY.
46-4001	XE VALIDATOR	1
46-0167	COINCO VALIDATOR (INCLUDES STACKER)	1
46-0200	MARS VALIDATOR (INCLUDES STACKER)	1

PART #	OTHER	QTY.
48-0006	HEATER ASSM.	1
48-1016	DRS HOPPER EXTENSION HARNESS (RIGHT)	1
48-1017	DRS HOPPER EXTENSION HARNESS (LEFT)	1
48-2115A	DUAL/HVX EXTENSION HARNESS	1
48-2115B	DUAL/HVX ADDITION HARNESS	1
60-0271	DUAL STACKER PLATE (RIGHT)	1
60-0272	DUAL STACKER PLATE (LEFT)	1
60-0273	STACKER BRACKET (RIGHT)	1
60-0274	STACKER BRACKET (LEFT)	1
60-0275	COMBINATION VALIDATOR BRACKET	1
60-0282A	SLIDER FACE PLATE ASSM. FOR USE W/ XE	1

APPENDIX A

1-H Harness Diagram

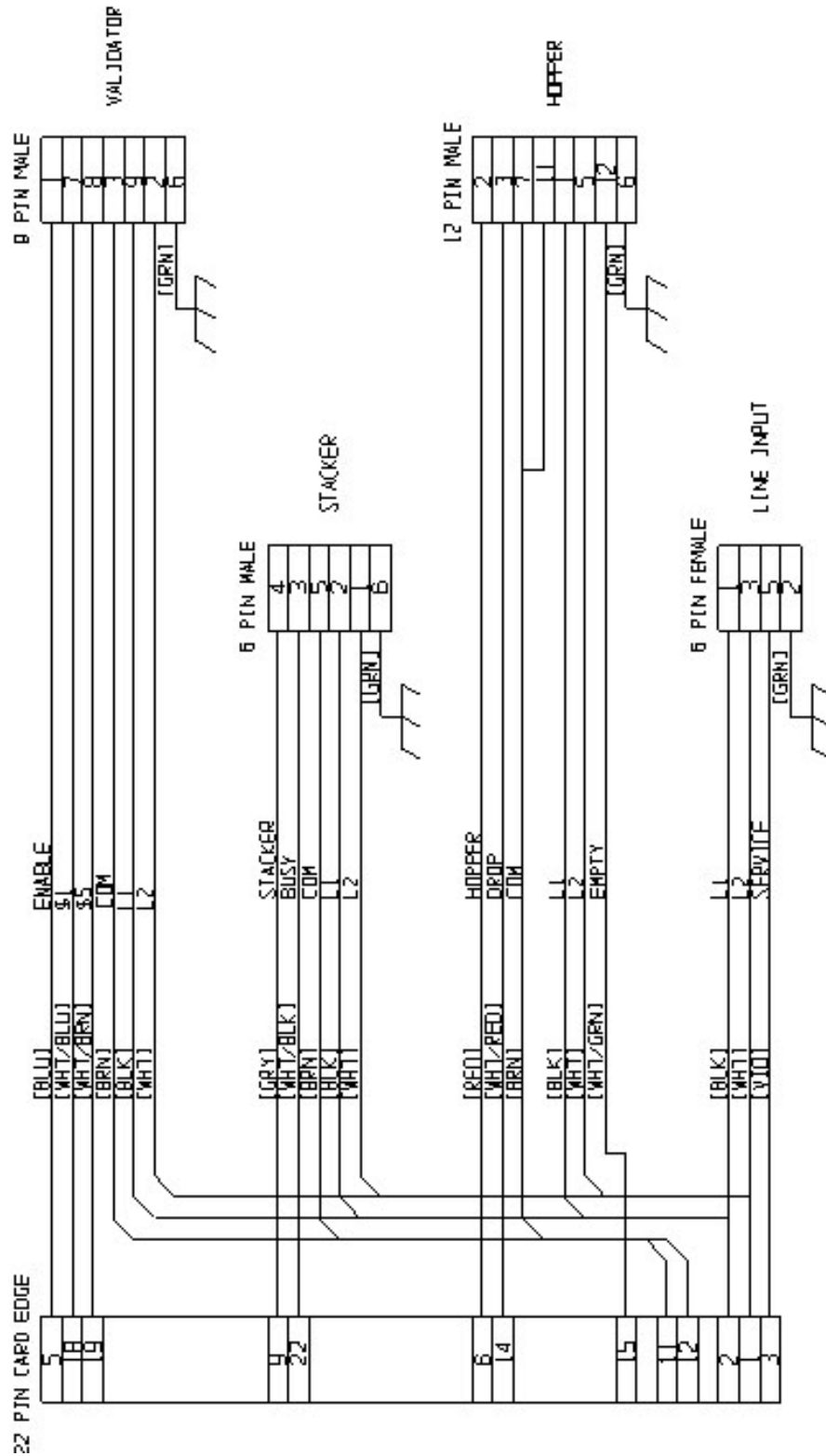

APPENDIX B

Bill Denomination Mylar Installation Instructions

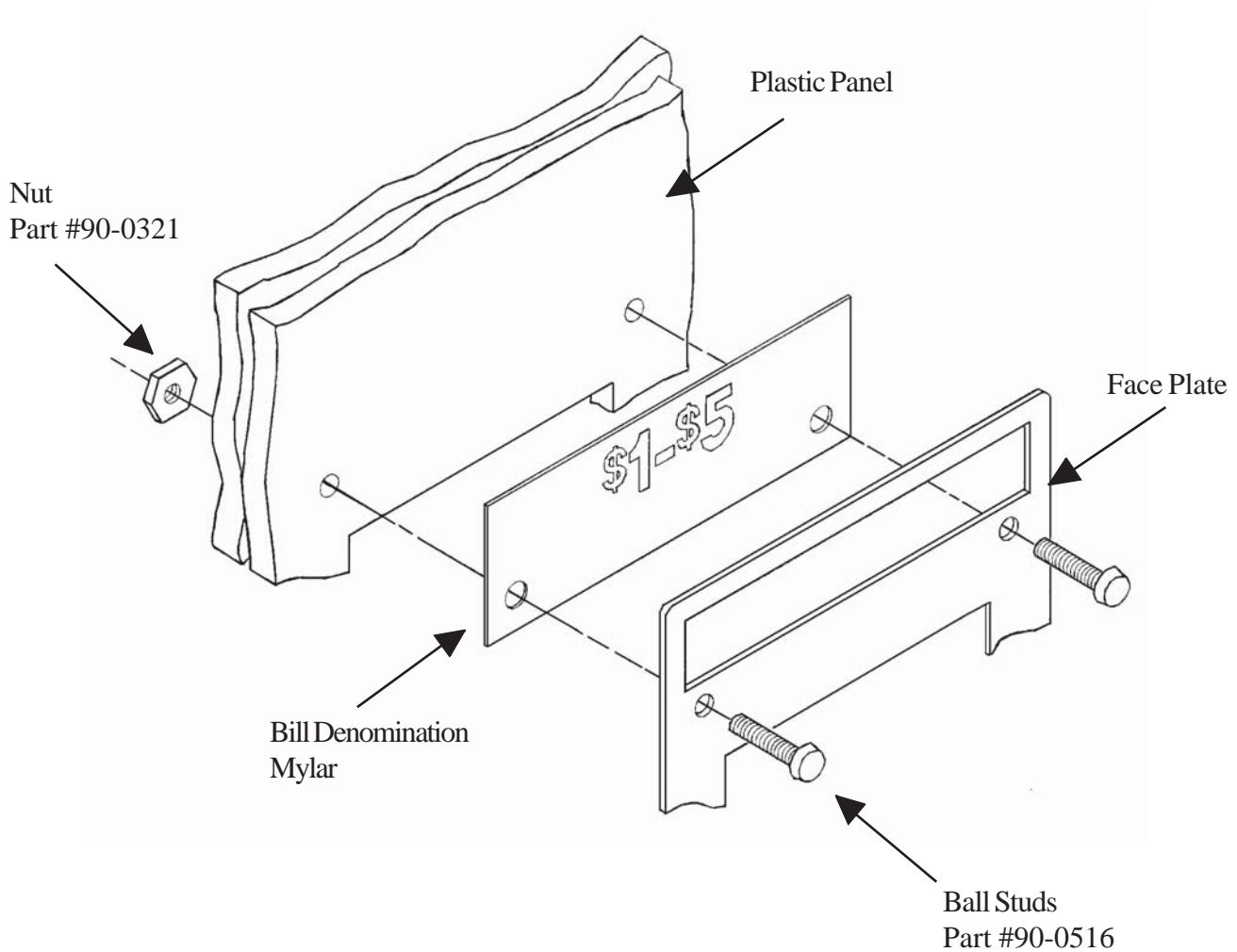

1. Loosen and remove the NUTS from the BALL STUDS.
2. Remove the BALL STUDS from the FACE PLATE.
3. Insert the BILL DENOMINATION MYLAR between the FACE PLATE and the PLASTIC PANEL until the holes in the BILL DENOMINATION MYLAR line up with the holes in the FACE PLATE.
4. Reinsert the BALL STUDS into the front of the FACE PLATE, through the BILL DENOMINATION MYLAR and the PLASTIC PANEL.
5. Replace the NUTS on the BALL STUDS and tighten.

LIMITED WARRANTY AGREEMENT OF HAMILTON MANUFACTURING CORP.

Hamilton Manufacturing Corp., an Ohio Corporation, (“Seller”) warrants to Purchaser that all new equipment shall be free from defects in material and factory workmanship for a period of one (1) year from the original shipping date. Hamilton Manufacturing Corp. further warrants if any part of said new equipment in Seller’s sole opinion, requires replacement or repair due to a defect in material or factory workmanship during said period, Seller will repair or replace said new equipment. Purchaser’s remedies and the liabilities and obligations of Seller herein shall be limited to repair or replacement of the equipment as Seller may choose, and Seller’s obligation to remedy such defects shall not exceed the Purchaser’s original cost for the equipment. Purchaser EXPRESSLY AGREES this is the EXCLUSIVE REMEDY under this warranty. There are no other express or implied warranties which extend beyond the face hereof. All warranty repair service must be performed by either a Factory Trained Service Representative or **HAMILTON MANUFACTURING CORP., 1026 Hamilton Drive, Holland, Ohio 43528 PHONE (419) 867-4858 or (800) 837-5561, FAX (419) 867-4867.**

The limited warranty for new equipment is conditioned upon the following:

1. The subject equipment has not, in the Seller’s sole opinion, been subjected to: accident, abuse, misuse, vandalism, civil disobedience, riots, acts of God, natural disaster, acts of war or terrorism.
2. The Seller shall not be liable for any expense incurred by Purchaser incidental to the repair or replacement of equipment and Purchaser shall assume full responsibility for any freight or shipping charges.
3. The coverage of this warranty shall not extend to expendable parts.
4. Purchaser shall have a warranty registration card on file with Seller prior to any claim in order for warranty protection to apply.
5. No warranty coverage is applicable to any equipment used for currency other than that specified at the time of the purchase.
6. Seller expressly disclaims any warranty that counterfeit currency will not activate said equipment.
7. Seller expressly disclaims any warranty for any losses due to bill manipulation or theft or loss of cash under any circumstances.

Seller further warrants all repair or service work performed by a factory trained representative or Hamilton Manufacturing Corp. for a period of ninety (90) days from the date the repair or service work was performed. Purchaser’s remedies and the liabilities and obligations of Seller herein shall be limited to repair or replacement of equipment as Seller may choose, and Seller’s obligation to remedy such defects shall not exceed the Purchaser’s depreciated value of the equipment. Purchaser EXPRESSLY AGREES this is an EXCLUSIVE REMEDY under this warranty. There are no other express or implied warranties on repair or service work performed by a factory trained representative or Hamilton Manufacturing Corp. which extend beyond the face hereof.

(See next page for additional provisions)

The limited warranty for repair and service work is conditioned upon the following:

1. The subject equipment has not, in the Seller's sole opinion, been subjected to: accident, abuse, misuse, vandalism, civil disobedience, riots, acts of God, natural disaster, acts of war or terrorism.
2. The Seller shall not be liable for any expense incurred by Purchaser incidental to the repair or replacement of equipment and Purchaser shall assume full responsibility for any freight or shipping charges.
3. The coverage of this warranty shall not extend to expendable parts.
4. Purchaser shall have a warranty registration card on file with Seller prior to any claim in order for warranty protection to apply.
5. No warranty coverage is applicable to any equipment used for currency other than that specified at the time of the purchase.
6. Seller expressly disclaims any warranty that counterfeit currency will not activate said equipment.
7. Seller expressly disclaims any warranty for any losses due to bill manipulation or theft or loss of cash under any circumstances.
8. No person or entity other than a factory trained representative or Hamilton Manufacturing Corp. has performed or attempted to perform the subject repair or service.

THIS AGREEMENT IS MADE WITH THE EXPRESS UNDERSTANDING THAT THERE ARE NO IMPLIED WARRANTIES THAT THE EQUIPMENT SHALL BE MERCHANTABLE, OR THAT THE GOODS SHALL BE FIT FOR ANY PARTICULAR PURPOSE. PURCHASER HEREBY ACKNOWLEDGES THAT IT IS NOT RELYING ON THE SELLER'S SKILL OR JUDGMENT TO SELECT OR FURNISH EQUIPMENT SUITABLE FOR ANY PARTICULAR PURPOSE AND THAT THERE ARE NO WARRANTIES WHICH EXTEND BEYOND THAT WHICH IS DESCRIBED HEREIN.

The Purchaser agrees that in no event will the Seller be liable for direct, indirect, or consequential damages or for injury resulting from any defective or non-conforming new, repaired or serviced equipment, or for any loss, damage or expense of any kind, including loss of profits, business interruption, loss of business information or other pecuniary loss arising in connection with this Limited Warranty Agreement, or with the use of, or inability to use the subject equipment regardless of Sellers knowledge of the possibility of the same.

Hamilton Manufacturing Corporation

1026 Hamilton Drive
Holland, OH 43528

Sales Phone: (888) 723-4858 **Sales Fax:** (419) 867-4850

Customer Service Phone: (800) 837-5561 **Customer Service Fax:** (419) 867-4857

Advanced Systems Phone: (866) 296-3365 **Advanced Systems Fax:** (419) 867-4857

Parts Phone: (866) 835-1721 **Parts Fax:** (419) 867-4867

Website: <http://www.hamiltonmfg.com>

Email Addresses:

service@hamiltonmfg.com

sales@hamiltonmfg.com

parts@hamiltonmfg.com

info@hamiltonmfg.com