

# **Hamilton Manufacturing Corporation**

---

1026 Hamilton Dr. Holland, OH 43528 • Phone: 419-867-4858/800-837-5561 • Fax: 419-867-4867 • [www.hamiltonmfg.com](http://www.hamiltonmfg.com)

## **ACW CRC Retrofit Installation Instructions #49-0563A**

**IMPORTANT:** The installation of this retrofit kit may interfere with other third party equipment already attached to the door of the ACW. Relocation of this retrofit card reader is **not** recommended. If this installation does interfere with other equipment, that equipment may need to be moved or eliminated.

1. Turn off power to the machine by turning off circuit breaker at distribution panel in equipment room.
2. Remove the following components from the machine:
  - Validator
  - Stacker
  - Controller
  - Hopper
  - Coin Mechanism
3. Remove faceplates and lexan from the door of the machine.
4. Attach the template (using the screws provided) through the left coin slot opening (Diagram A).
5. Center punch through the template to mark the three hole locations (Diagram A).
6. Remove the template.
7. Drill three holes in the door (Diagram A). It is recommended to start with a smaller drill size than is needed for the holes and work your way up to the correct size. The use of cutting oil is also recommended. Press hard and drill slowly.
8. Clean oil and metal flakes thoroughly from the door and cabinet.
9. Reattach the lexan and faceplates to the door.
10. Drill holes in the lexan to match the holes in the door from the inside of machine.
11. Use a vacuum to remove debris from inside the machine.
12. An outlet will be needed in the cabinet. The necessary utility box, cover and socket are provided. Please have this installed by qualified personnel only.

**Important: Remove power to machine by turning off the circuit breaker in the equipment room. Turning off the red ON/OFF switch inside the ACW does not remove power from the electrical service box the outlet is added to.**

13. Feed cord through the large hole and attach the card reader using the four screws and lock washers provided.
14. This step may not be necessary for all machines. To determine if it is, locate the ACW's serial communication connector. (Refer to Diagram B) This connector is usually located beside the ACW

Controller, and can be identified as a short harness branch with a 4-position white connector. It is typically used for connecting a portable serial printer to the system, so there should not be anything plugged into it at this time. For older style ACW's, this plug may be located inside a metal bracket mounted to the inside of the cabinet door. Once the connector is located, determine if there are three or four positions already filled. If all four positions are used, this step is not necessary. If only three positions are filled, insert the round terminal of the ACW-CRC addition harness into position four of the ACW communications plug. Route the wire neatly and insert the other end into position 13 of the 18-position card edge connector.

15. Place the CRC Box in the machine under the Hopper shelf with the connectors facing the door.
  - a. Remove the Surge Protector from box and place the enclosed phone cable into the end labeled "EQUIP".
  - b. Plug the other end of the phone cable into the ACW-CRC computer.
  - c. Insert the forked terminal under the head of the supplied #8-32 x 1/2" screw (drilling a 3/16" hole if necessary). See Diagram D.
  - d. Secure screw with the supplied #8 nylon locking nut, making sure terminal stays under screw head.
  - e. Attach the Surge Protector to the hopper support plate using the provided hook and loop tape.
  - f. Plug the phone line into the remaining jack on the Surge Protector.
16. Add wire harness as shown in Diagram C.
17. Replace components into the machine. When replacing the Controller check if the Controller that was removed has a cover with a cut out window to view the display. If it does, remove it from the old Controller and install on the replacement. Newer machines with the additional weather shroud around the Controller will have Controllers that do not have (or need) this cover.
18. Secure harness with the wire ties provided. Choose a placement where the harness will not get pinched or will not interfere with anything.
19. Attach decals.
20. When powering the machine up, two programming categories may need to be adjusted. First, in older cabinets the display window is smaller than the currently used display. If you can not see the first character of the display when the Controller is installed in the cabinet, set the programming category called "SET DISPLAY STYLE" to "RETROFIT (18 CHAR)". Secondly, if your Hopper is a model HGP, the programming category "SET HOPPER STYLE" will have to be set to "OLD STYLE HOPPER".

# Diagram A

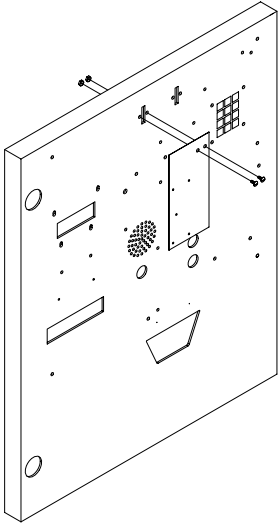

ATTACH TEMPLATE

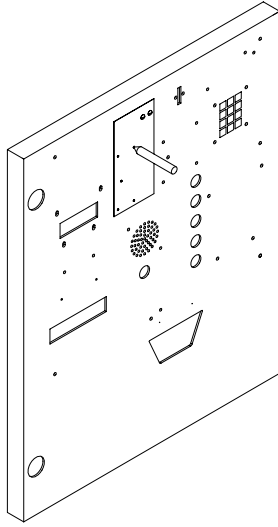

MARK HOLE LOCATIONS

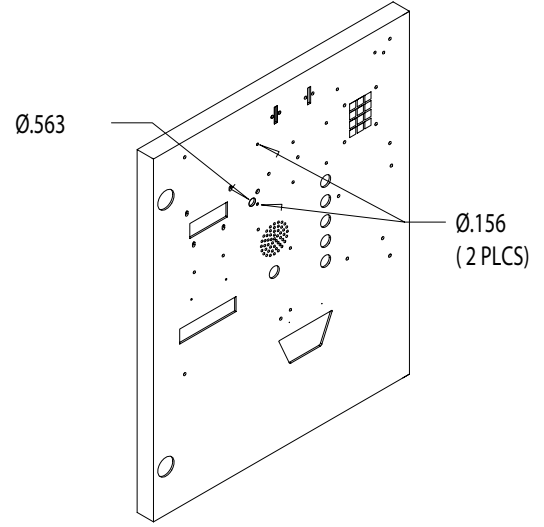

DRILL TO DIA. NOTED

# Diagram B

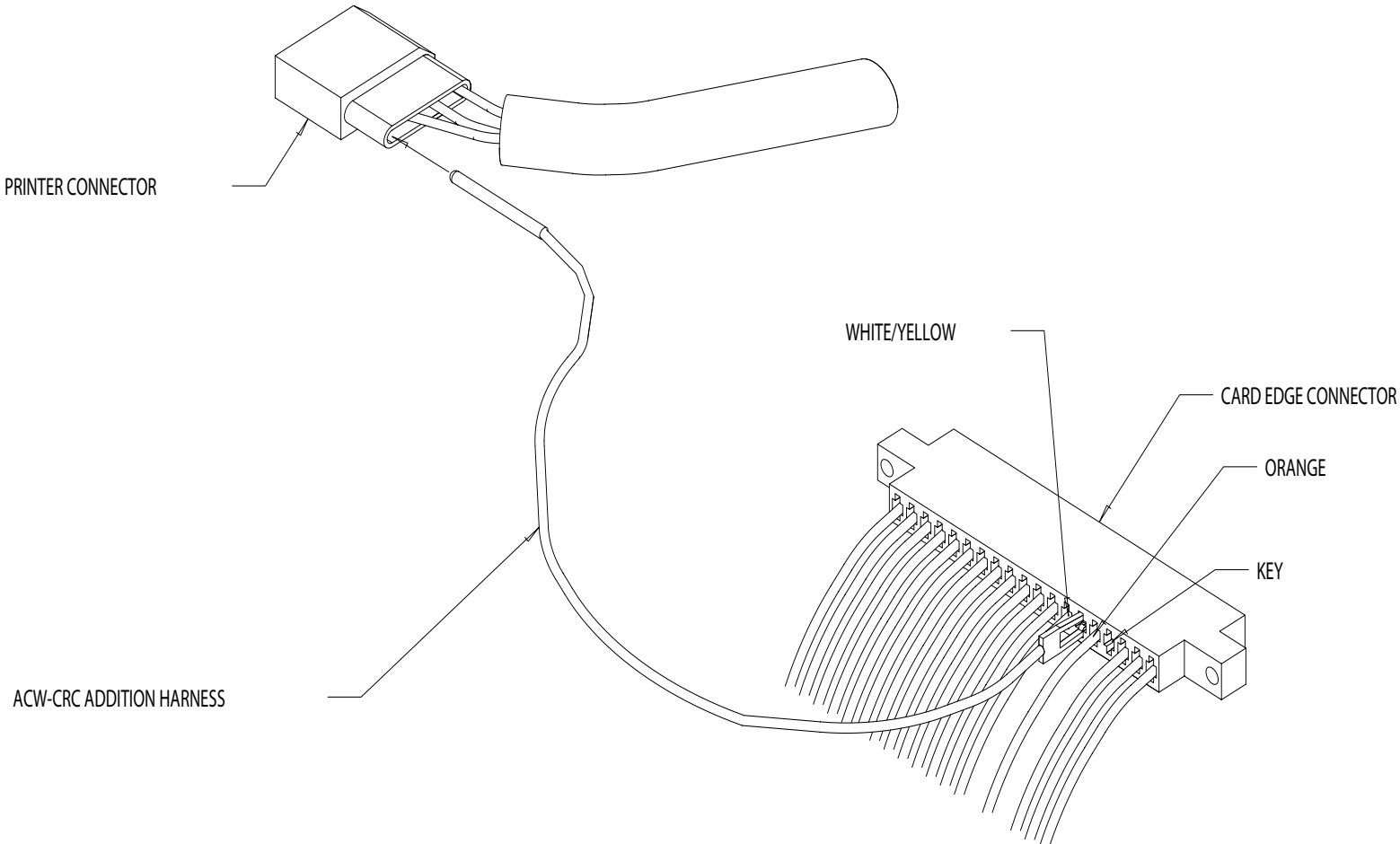

WIRE COLORS GIVEN ARE THE MOST COMMON CONFIGURATION AND NOT THE ONLY POSSIBILITY.

# Diagram C

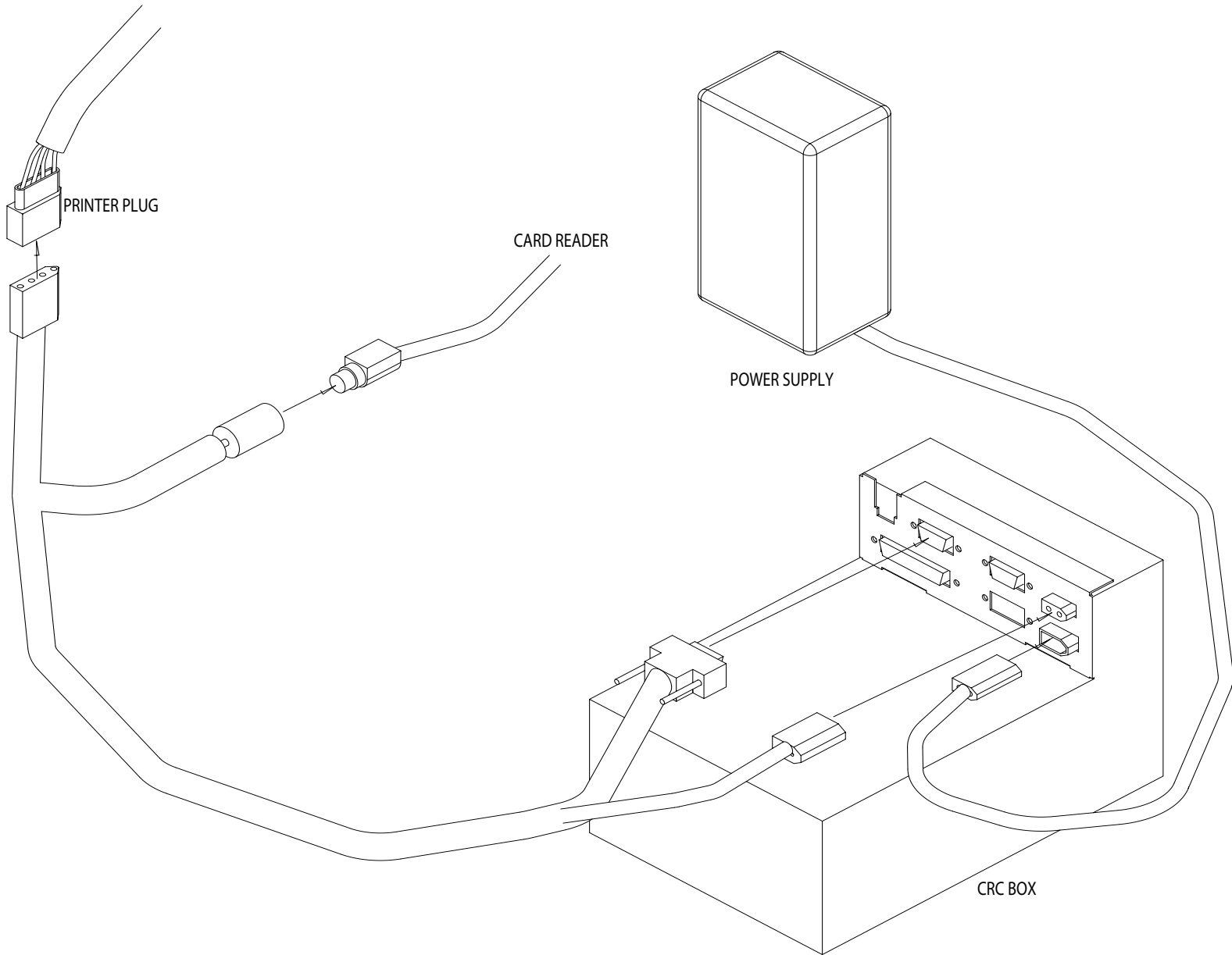

# Diagram D

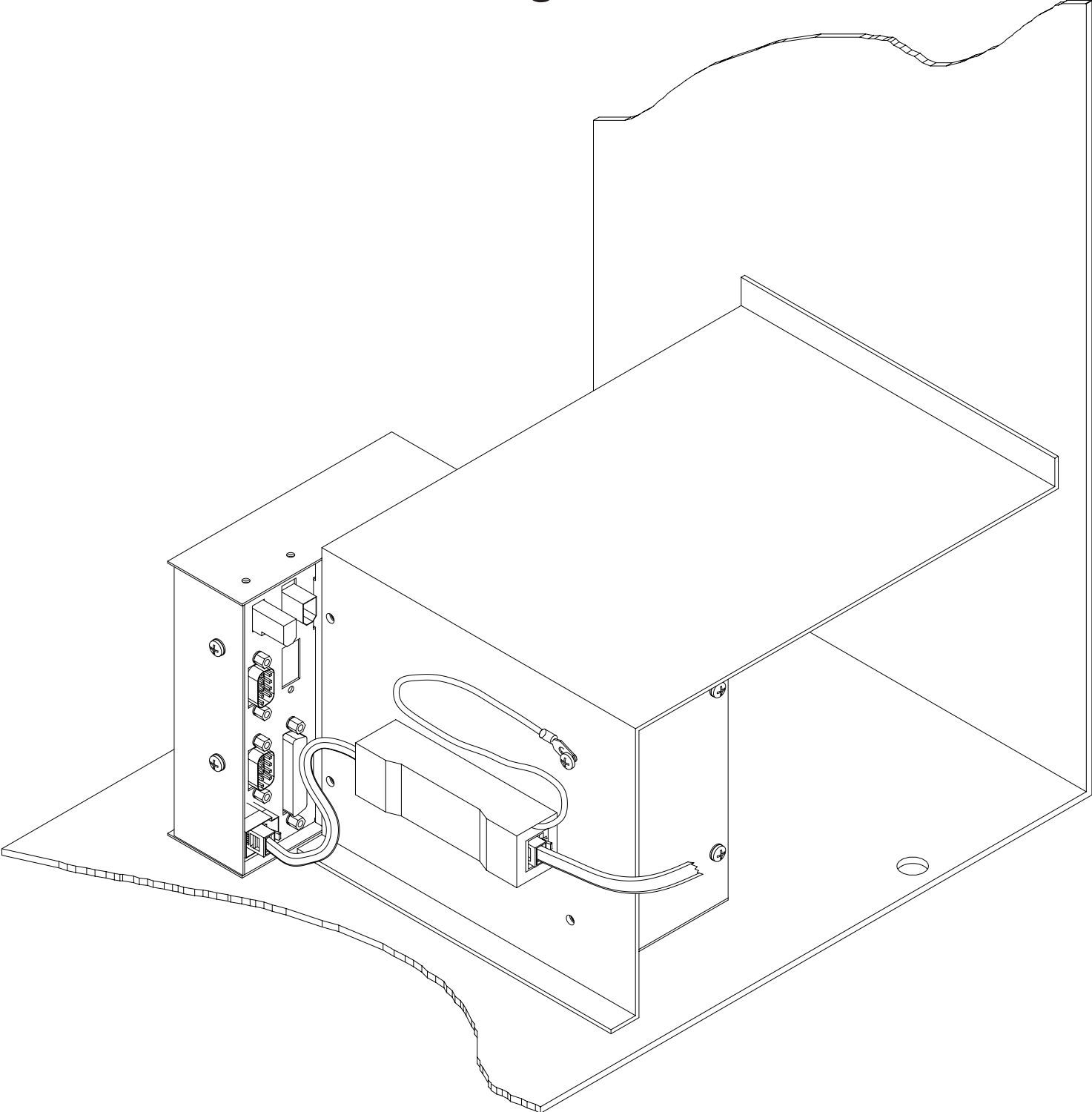

## Recommended Mounting

# **LIMITED WARRANTY AGREEMENT**

## **OF HAMILTON MANUFACTURING CORP.**

Hamilton Manufacturing Corp., an Ohio Corporation, (“Seller”) warrants to Purchaser that all new equipment shall be free from defects in material and factory workmanship for a period of one (1) year from the original shipping date. Hamilton Manufacturing Corp. further warrants if any part of said new equipment in Seller’s sole opinion, requires replacement or repair due to a defect in material or factory workmanship during said period, Seller will repair or replace said new equipment. Purchaser’s remedies and the liabilities and obligations of Seller herein shall be limited to repair or replacement of the equipment as Seller may choose, and Seller’s obligation to remedy such defects shall not exceed the Purchaser’s original cost for the equipment. Purchaser EXPRESSLY AGREES this is the EXCLUSIVE REMEDY under this warranty. There are no other express or implied warranties which extend beyond the face hereof. All warranty repair service must be performed by either a Factory Trained Service Representative or **HAMILTON MANUFACTURING CORP., 1026 Hamilton Drive, Holland, Ohio 43528 PHONE (419) 867-4858 or (800) 837-5561, FAX (419) 867-4867.**

The limited warranty for new equipment is conditioned upon the following:

1. The subject equipment has not, in the Seller’s sole opinion, been subjected to: accident, abuse, misuse, vandalism, civil disobedience, riots, acts of God, natural disaster, acts of war or terrorism.
2. The Seller shall not be liable for any expense incurred by Purchaser incidental to the repair or replacement of equipment and Purchaser shall assume full responsibility for any freight or shipping charges.
3. The coverage of this warranty shall not extend to expendable parts.
4. Purchaser shall have a warranty registration card on file with Seller prior to any claim in order for warranty protection to apply.
5. No warranty coverage is applicable to any equipment used for currency other than that specified at the time of the purchase.
6. Seller expressly disclaims any warranty that counterfeit currency will not activate said equipment.
7. Seller expressly disclaims any warranty for any losses due to bill manipulation or theft or loss of cash under any circumstances.
8. Use of the equipment for anything other than its intended and designed use will void the Limited Warranty Agreement. Use of equipment for anything other than its intended and designed use includes, but is not limited to, downloading software/applications not certified by Seller such as e-mail, spyware, screen savers, viruses, worms, third party software, web search engines, cookies, spam, desktop applications, games, web surfing, etc.

Seller further warrants all repair or service work performed by a factory trained representative or Hamilton Manufacturing Corp. for a period of ninety (90) days from the date the repair or service work was performed. Purchaser’s remedies and the liabilities and obligations of Seller herein shall be limited to repair or replacement of equipment as Seller may choose, and Seller’s obligation to remedy such defects shall not exceed the Purchaser’s depreciated value of the equipment. Purchaser EXPRESSLY AGREES this is an



EXCLUSIVE REMEDY under this warranty. There are no other express or implied warranties on repair or service work performed by a factory trained representative or Hamilton Manufacturing Corp. which extend beyond the face hereof.

The limited warranty for repair and service work is conditioned upon the following:

1. The subject equipment has not, in the Seller's sole opinion, been subjected to: accident, abuse, misuse, vandalism, civil disobedience, riots, acts of God, natural disaster, acts of war or terrorism.
2. The Seller shall not be liable for any expense incurred by Purchaser incidental to the repair or replacement of equipment and Purchaser shall assume full responsibility for any freight or shipping charges.
3. The coverage of this warranty shall not extend to expendable parts.
4. Purchaser shall have a warranty registration card on file with Seller prior to any claim in order for warranty protection to apply.
5. No warranty coverage is applicable to any equipment used for currency other than that specified at the time of the purchase.
6. Seller expressly disclaims any warranty that counterfeit currency will not activate said equipment.
7. Seller expressly disclaims any warranty for any losses due to bill manipulation or theft or loss of cash under any circumstances.
8. No person or entity other than a factory trained representative or Hamilton Manufacturing Corp. has performed or attempted to perform the subject repair or service.
9. Using equipment which has been serviced or repaired for anything other than its intended or designed use such as downloading software applications not certified by Seller will void the Limited Warranty Agreement. This includes software/applications such as e-mail, spyware, screen savers, viruses, worms, third party software, web search engines, cookies, spam, desktop applications, games, web surfing, etc.

THIS AGREEMENT IS MADE WITH THE EXPRESS UNDERSTANDING THAT THERE ARE NO IMPLIED WARRANTIES THAT THE EQUIPMENT SHALL BE MERCHANTABLE, OR THAT THE GOODS SHALL BE FIT FOR ANY PARTICULAR PURPOSE. PURCHASER HEREBY ACKNOWLEDGES THAT IT IS NOT RELYING ON THE SELLER'S SKILL OR JUDGMENT TO SELECT OR FURNISH EQUIPMENT SUITABLE FOR ANY PARTICULAR PURPOSE AND THAT THERE ARE NO WARRANTIES WHICH EXTEND BEYOND THAT WHICH IS DESCRIBED HEREIN.

The Purchaser agrees that in no event will the Seller be liable for direct, indirect, or consequential damages or for injury resulting from any defective or non-conforming new, repaired or serviced equipment, or for any loss, damage or expense of any kind, including loss of profits, business interruption, loss of business information or other pecuniary loss arising in connection with this Limited Warranty Agreement, or with the use of, or inability to use the subject equipment regardless of Sellers knowledge of the possibility of the same.

# **Hamilton Manufacturing Corp.**

1026 Hamilton Drive  
Holland, OH 43528

**Sales Phone:** (888) 723-4858    **Sales Fax:** (419) 867-4850

**Customer Service Phone:** (800) 837-5561    **Customer Service Fax:** (419) 867-4857

**Advanced Systems Phone:** (866) 296-3365    **Advanced Systems Fax:** (419) 867-4857

**Parts Phone:** (866) 835-1721    **Parts Fax:** (419) 867-4867

**Website:** <http://www.hamiltonmfg.com>

**Email Addresses:**

[service@hamiltonmfg.com](mailto:service@hamiltonmfg.com)

[sales@hamiltonmfg.com](mailto:sales@hamiltonmfg.com)

[parts@hamiltonmfg.com](mailto:parts@hamiltonmfg.com)

[info@hamiltonmfg.com](mailto:info@hamiltonmfg.com)